



On-board Galvanic Isolation for High Voltages using PCB-integrated optical waveguides

Dr. Nikolaus Flöry, vario-optics ag

April 19th, Brussels

Who we are

- SME based in Heiden, Switzerland
- Spin-off from Varioprint AG (PCB)
- Designer & Manufacturer of photonic boards
- Applications & Markets:
 - Photonic Sensing (Medical, Industrial, Environmental)
 - High-speed on-board communication (Telecom, Aerospace)
 - Photonic chip packaging (Telecom, Sensing,...)



Photonic Boards?

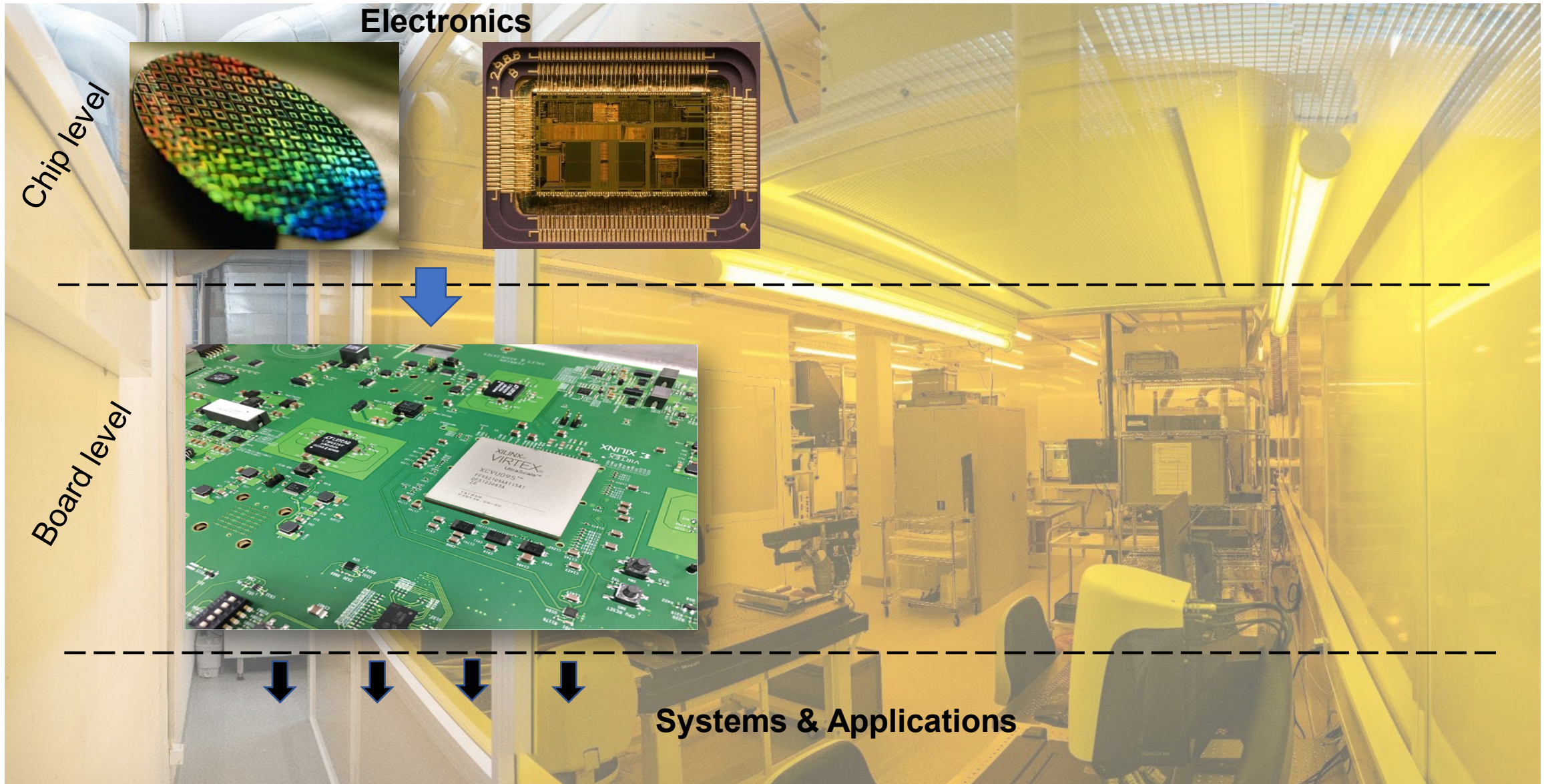

Photonic Boards?

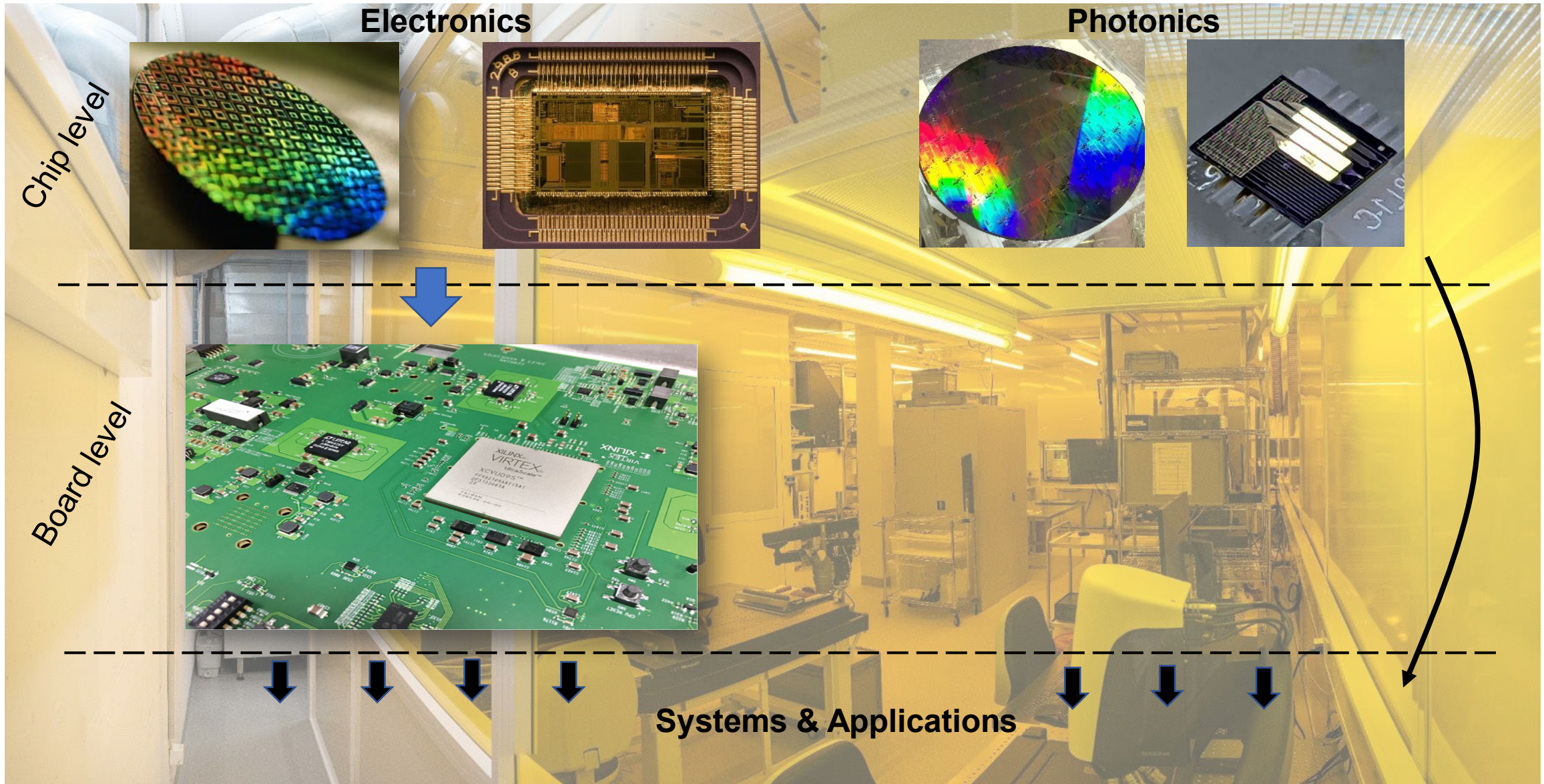

Photonic Boards?

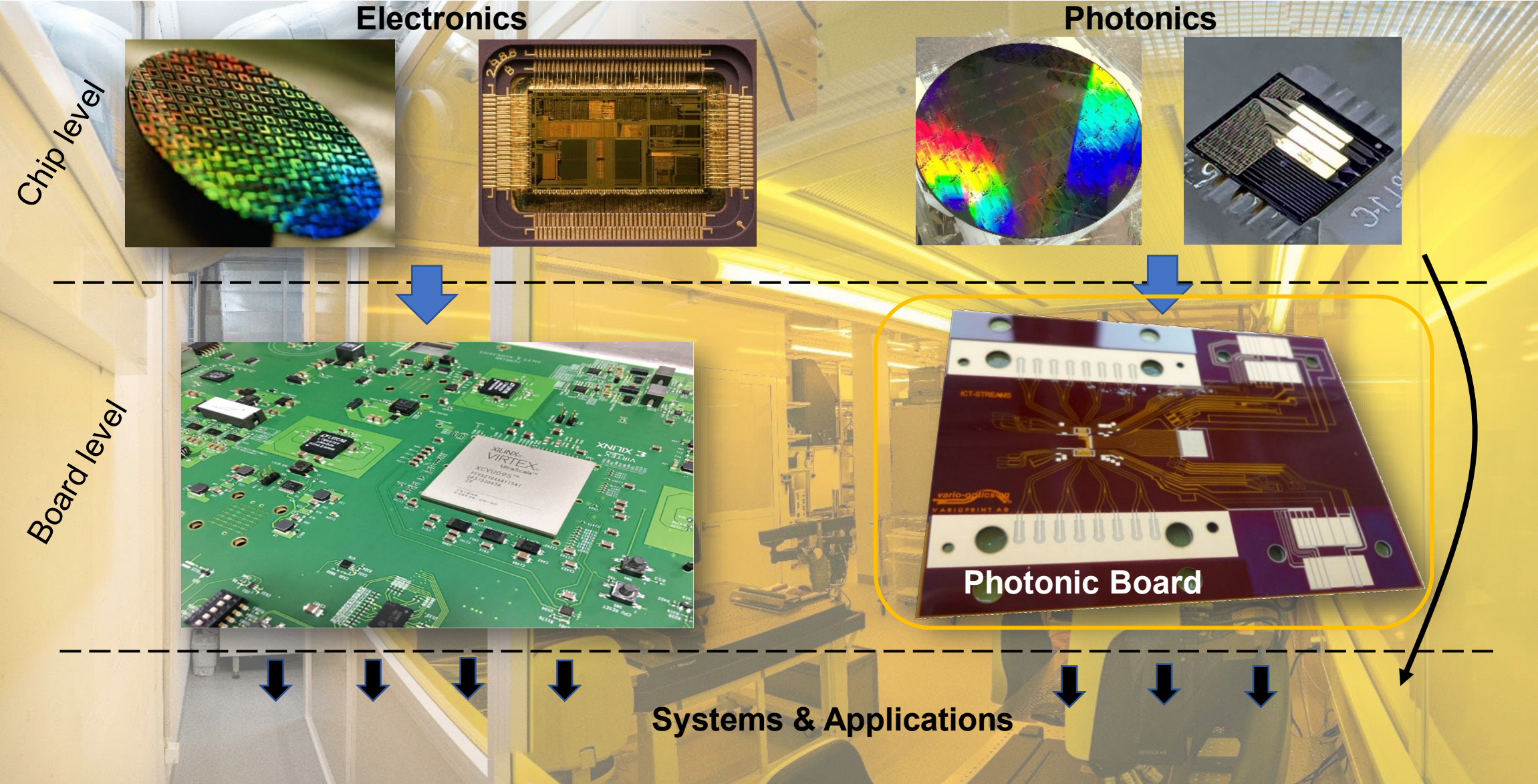

Our solution: on-board photonics

- Vario-optics **embedded waveguide technology** brings photonics to the board level **inside the module**
- Combination and integration of **optical** and **electrical connections** is a key-enabler for optical transceivers, co-packaged optics, integrated photonics etc



Conventional (PCB + glass fibers)

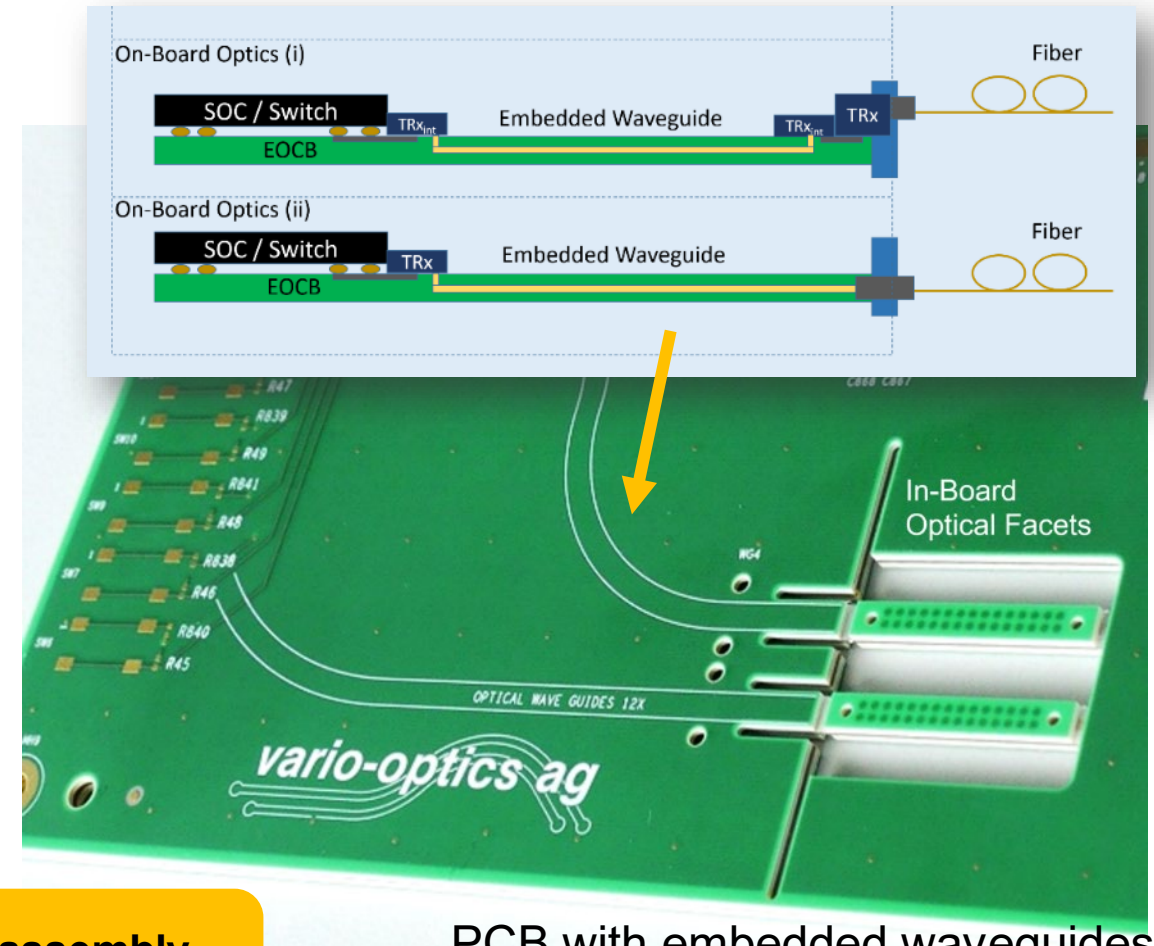

Massive assembly cost-reduction

PCB with embedded waveguides

Features of Photonics Boards

Planar **optical waveguides** & structures, optimized for a **broad wavelength spectrum**

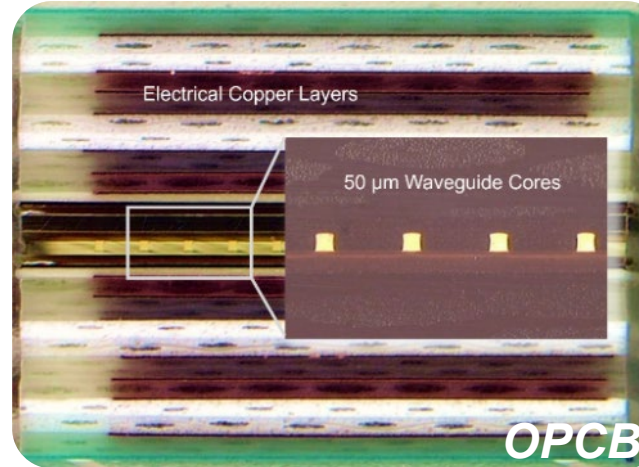

Combination with PCBs: integration of **optical and electrical connections**

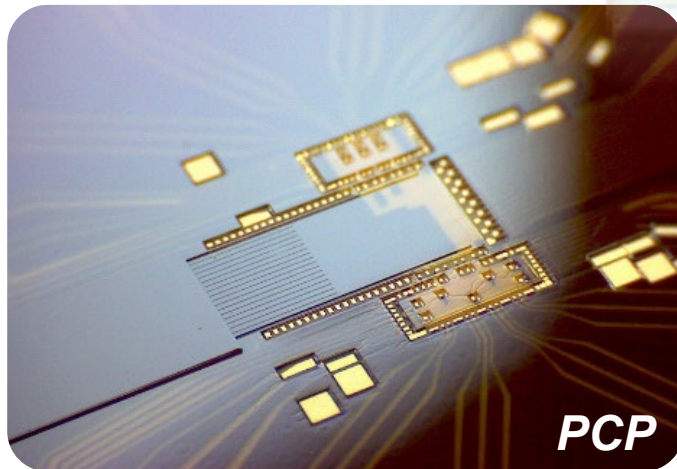
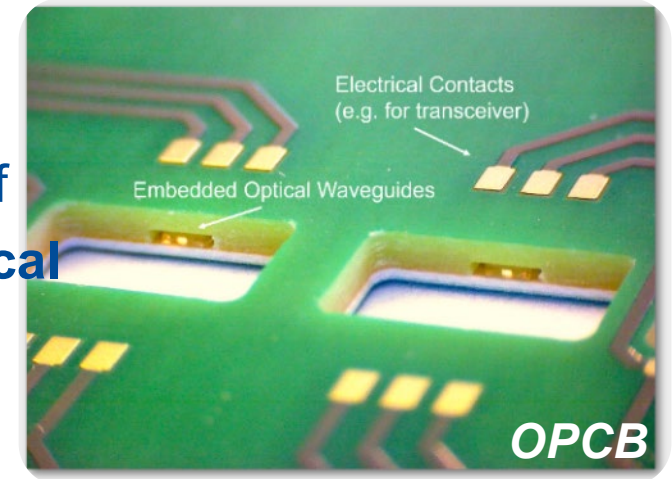

High integration density for any number of optical channels

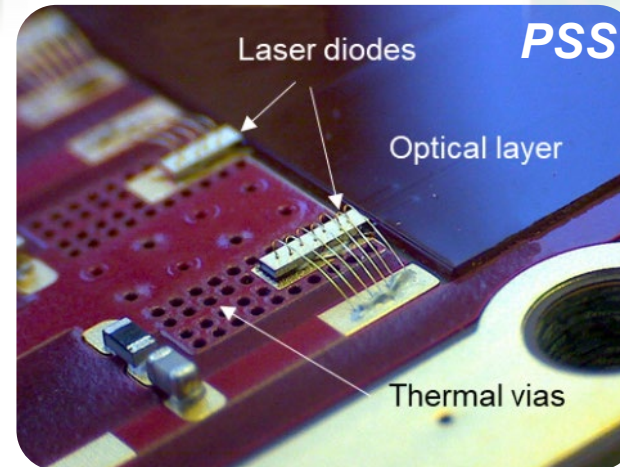

Access to photonic functionalities via **standardized e/o interfaces**

Megatrend 1: Digitalization

- Datacenter traffic is **exponentially growing**
- New emerging technologies such as **AI, IoT** demand even more bandwidth;

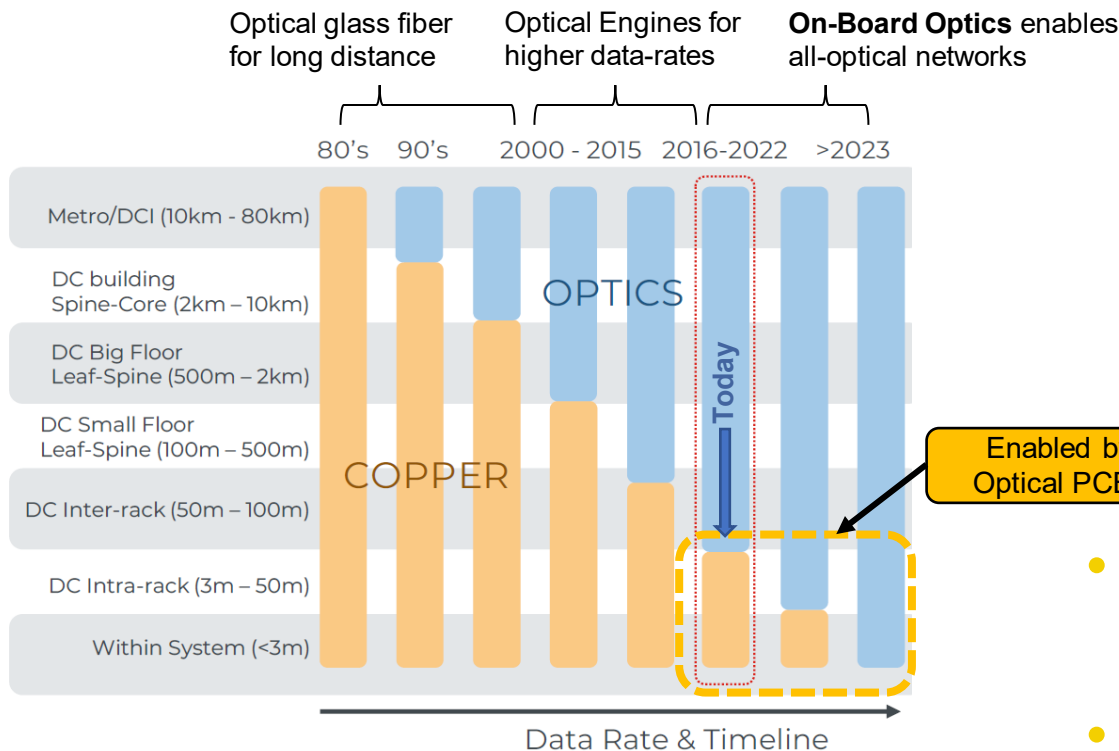
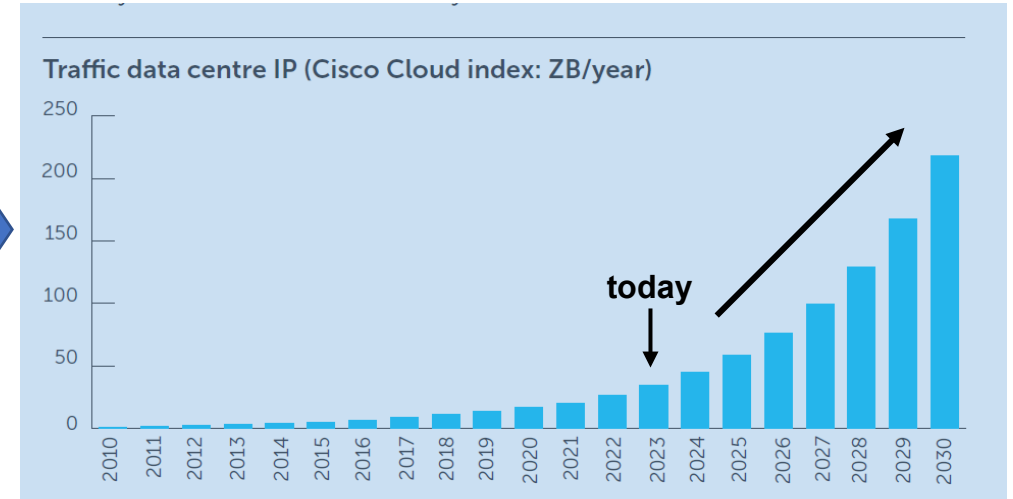

Photonics is the key-enabling technology of our modern, mobile and digitally connected society.

- Current technologies (electronics) fail to keep up with higher data-rates
- Shift to Optics/Photonics is required!

Yole 2022 market report on Optical Transceiver for Datacom & Telecom Market

Megatrend 2: Miniaturization

- Cost & performance requirements drive miniaturization
- Systems get more and more complex & require high integration density
- Dense co-integration of electrical-, optical and mechanical components required

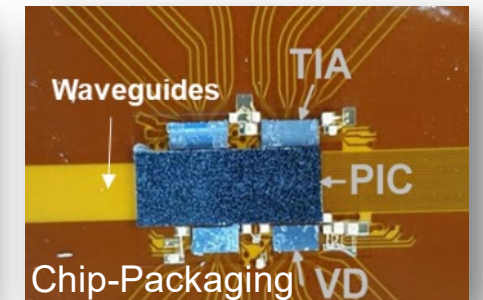
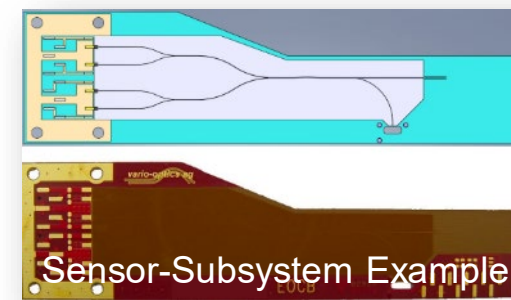
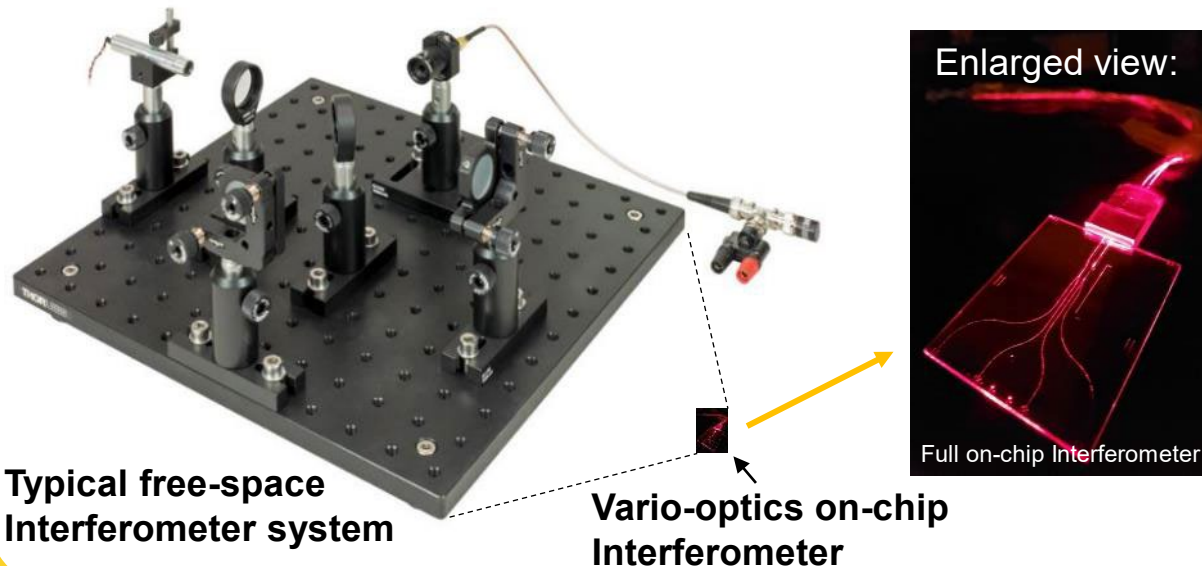

vario-optics enables completely new form factors:

- Denso co-integration of electrical & optical components
- Miniaturization by using planar waveguides
- Small devices increase stability & robustness

Markets & Applications

1) Photonic Sensor Subsystems (PSS)

(Medical, Industrial, Chemical, Aerospace)

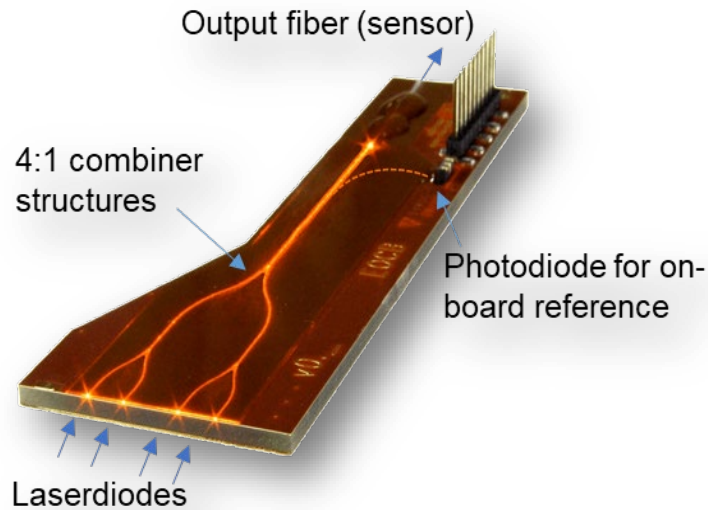

- Miniaturization & cost reduction
- High integration of electronics and photonics
- On-chip interferometry

2) Optical PCB (OPCB)

(Telecom, Aerospace, Defense, Industrial)

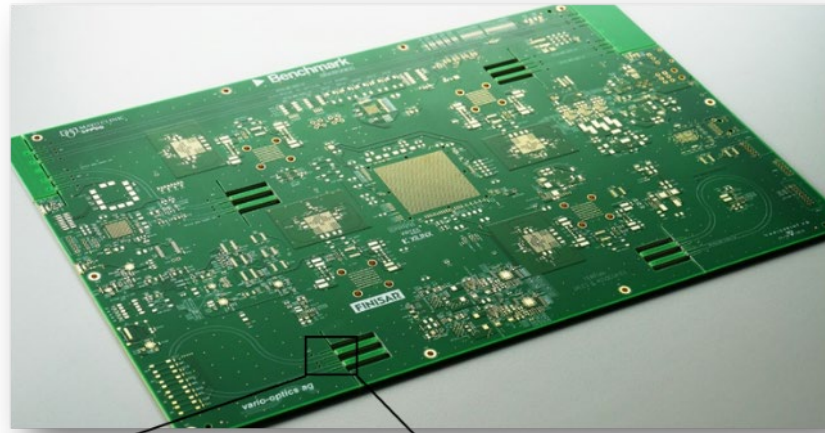

- Electro-optic boards
- Highest data-rates
- Massive power reduction using optical signals

3) Photonic Chip Packaging (PCP)

Telecom, Industrial, Avionics)

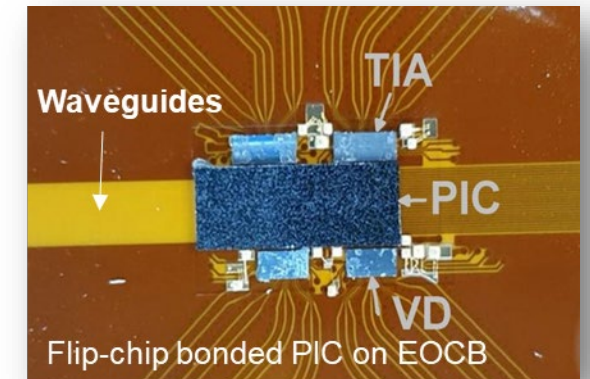

- dense integration of electronic and photonic interfaces
- Multi-port
- high data-rates, low power consumption

Markets & Applications

1) Photonic Sensor Subsystems (PSS)

(Medical, Industrial, Chemical, Aerospace)

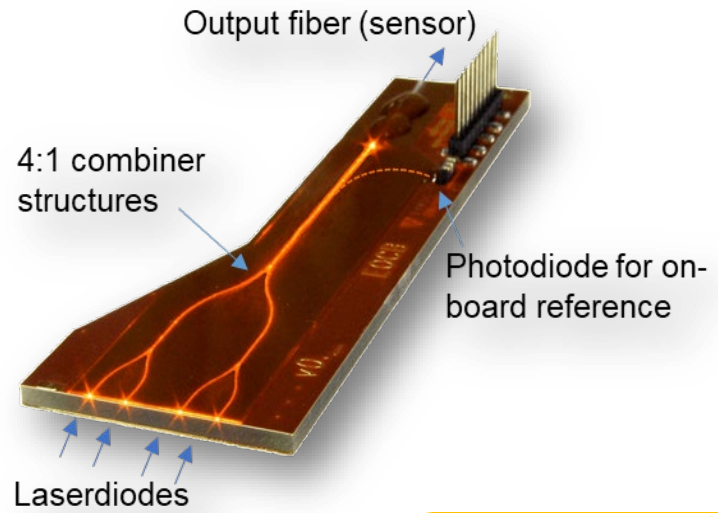

- Miniaturization & integration of electronics and photonics
- High integration of electronics and photonics
- On-chip interference

2) Optical PCB (OPCB)

(Telecom, Aerospace, Defense, Industrial)

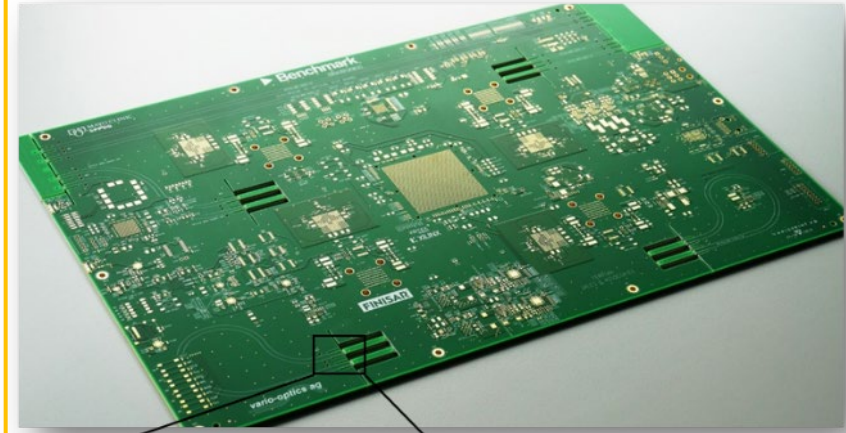

3) Photonic Chip Packaging (PCP)

Telecom, Industrial, Avionics)

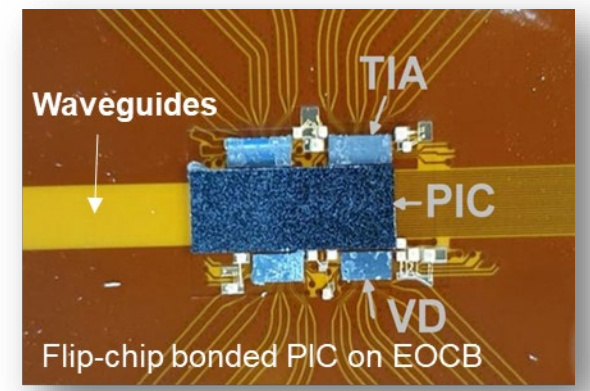

- dense integration of electronic and photonic interfaces
- Multi-port
- high data-rates, low power consumption

Galvanic Separation

boards
ates
r reduction using

On-board Galvanic Separation

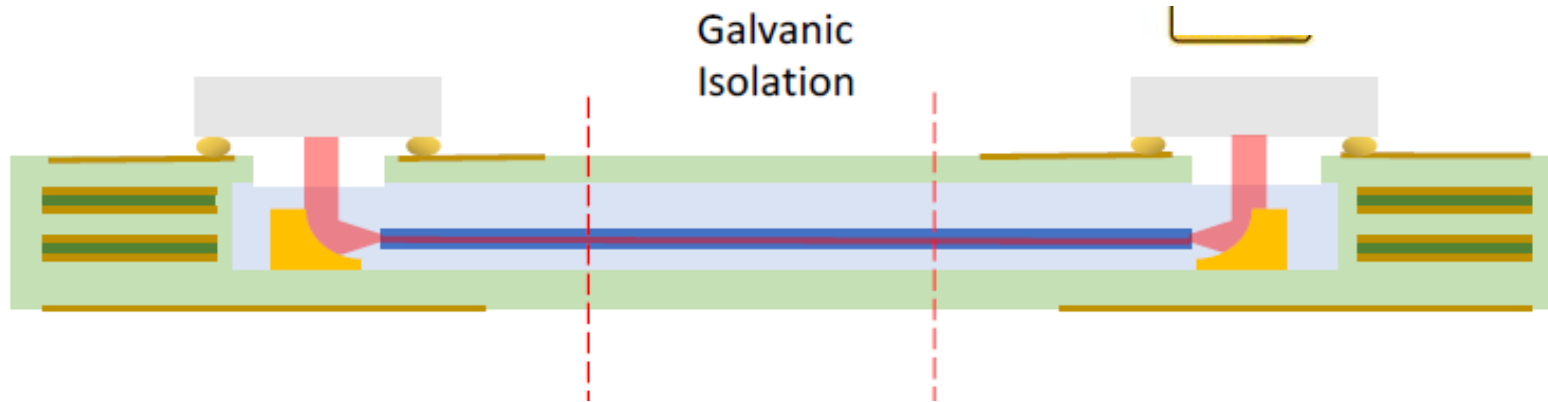

- **Separation of any voltage levels**
the optical length can be adjusted to the needs of the application
- **Very high bandwidth**
the bandwidth of optical signaling is not limited (up to multiple GHz)

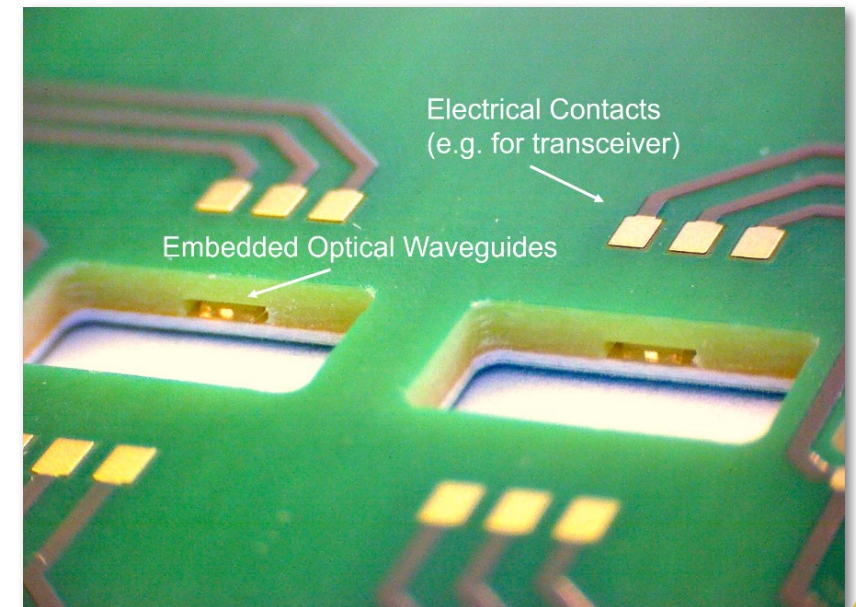

On-board Galvanic Separation

- **Synchronous signals for low loss and timing critical applications**
the layout of optical waveguide supports any design, a.o. also splitters. This enables absolutely synchronous control of e.g. power switches fed by a single optical transmitter.
- **Robust against harsh environments**
no electro-magnetic distortion, robust to high temperature and vibration (thanks to the integration into the electrical circuit board)

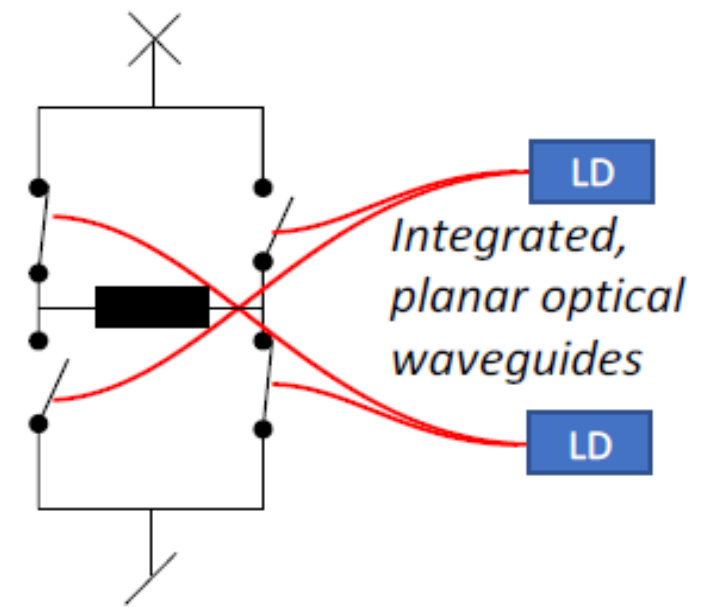
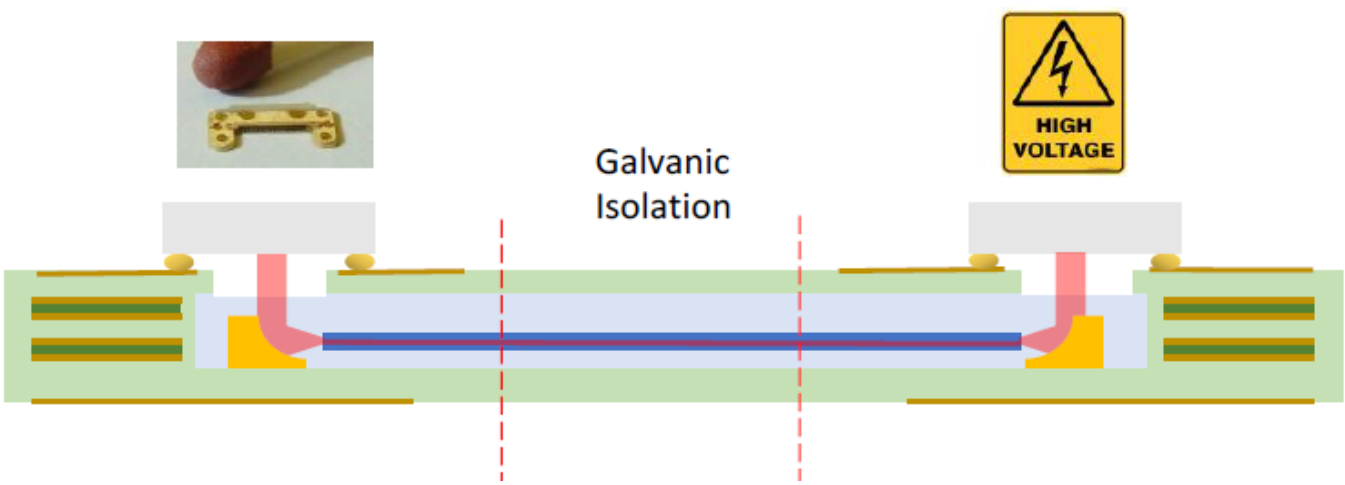

On-board Galvanic Separation

- **Applications:**

- High Voltage Systems with many connections
 - EV, Rail, Industrial
- Hermetically sealed systems
 - Embedded in PCB

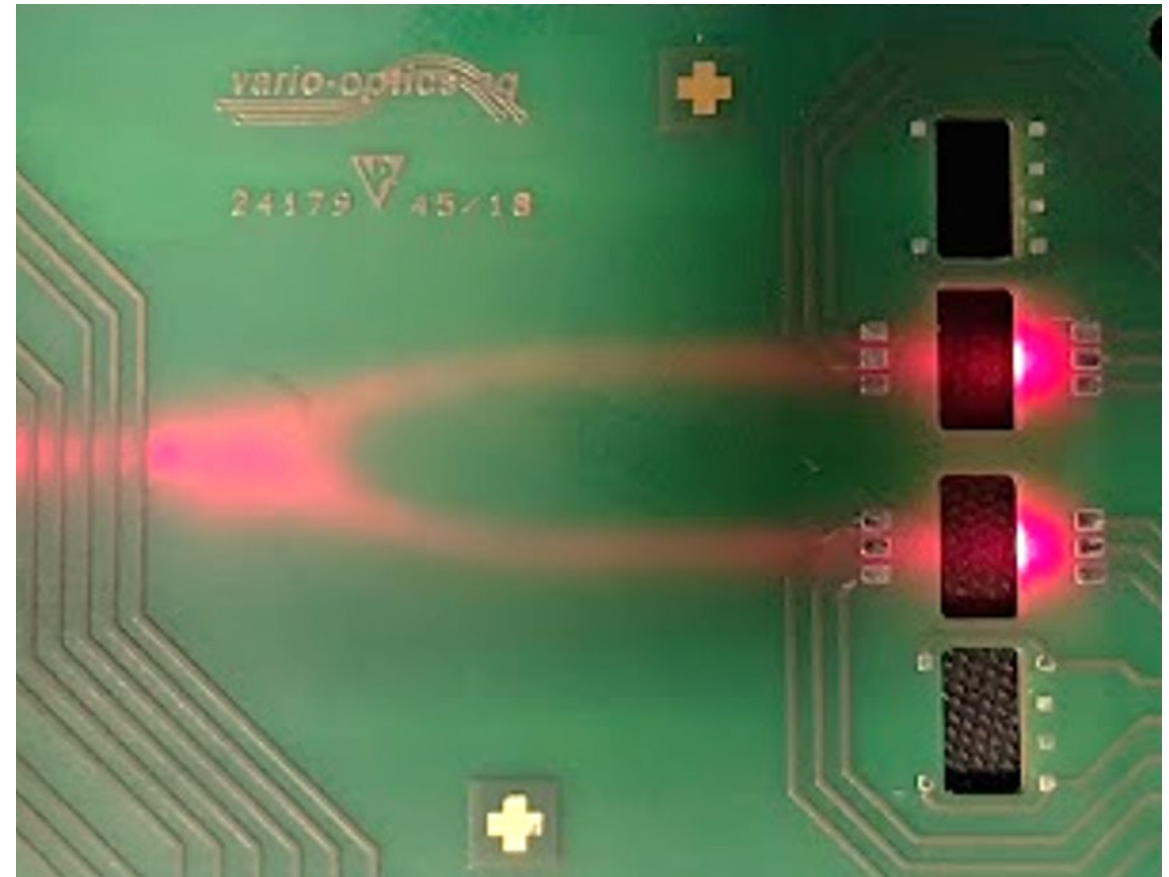
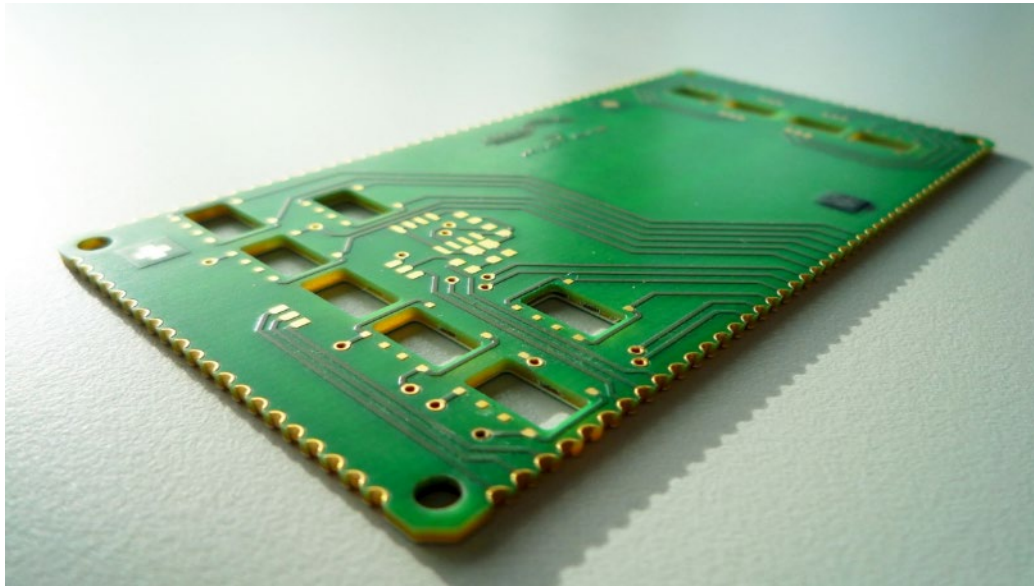

Engineering & Simulation Competences

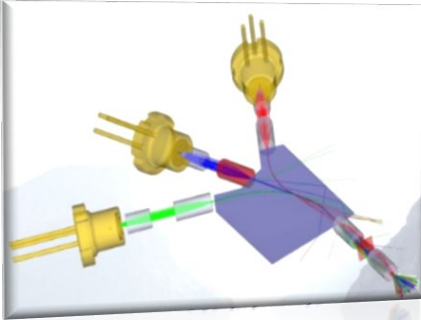

- **Best-in-class technical & development expertise**
customer-specific photonic solutions
- **Strong competences in Simulation & Layout**
Optical and electrical

Scalable manufacturing process, easy-to-use interfaces

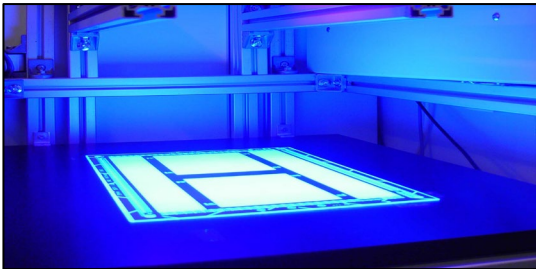

- **Lithographic manufacturing process**
Scalable and cost-effective; Ready for mass-production
- **Robust Photonic Packaging Solutions**
Standardized optical & electrical interfaces

Customized Engineering to Volume Production

Vario-optics supports customers from feasibility and engineering phase till series production



Nikolaus Flöry
n.floery@vario-optics.ch



The Future is
Bright !

Contact:

vario-optics ag
Mittelbissastrasse 7
9410 Heiden / Switzerland
+41 71 898 80 62
info@vario-optics.ch
www.vario-optics.ch