



How does the digital control unlock the full capabilities of GaN in power supply ?

PE International 2023

18th April 2023

TREND DRIVING POWER ELECTRONICS

The electrification of the world accelerates the need for more power converters. ODMs & OEMs are looking for more **power dense, efficient, smart & cost-effective** solutions.



WIDE BAND GAP MATERIAL ARE KEY DRIVERS...

GaN on silicon is the most suitable, scalable and cost-effective technology to replace silicon for all applications connected to the grid (voltage range from 100V to 1200V).

Enabling **high power density, high power efficiency and reduced BOM cost.**



- **High switching speed 20X**
- **Low Ron.S**

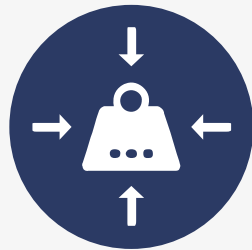

**Smaller & Lighter
(2-3 times)**



**High Efficiency
(2-4 times less losses)**



**Lower system BOM Cost
(10 to 50%)**



... BUT GAN IS STILL PERFECTIBLE

Silicon Analog controllers are **not suitable** for maximizing the GaN benefits.

The maximum control frequency is limited to some 100kHz while GaN can switch at MHz !
→ **Limits power density and efficiency**

We need at least 2 different analog controllers to manage an AC-DC GaN power supply
→ **System design complexity, long fine tuning, worse ROI**

Few analog GaN controllers available on the market today
→ **Supply issues**

Regulation using a continuous signal generates issues such as ringing, over/undershoot,
→ **Low efficiency, lifespan**

No smart possibilities with analog control

Power Density

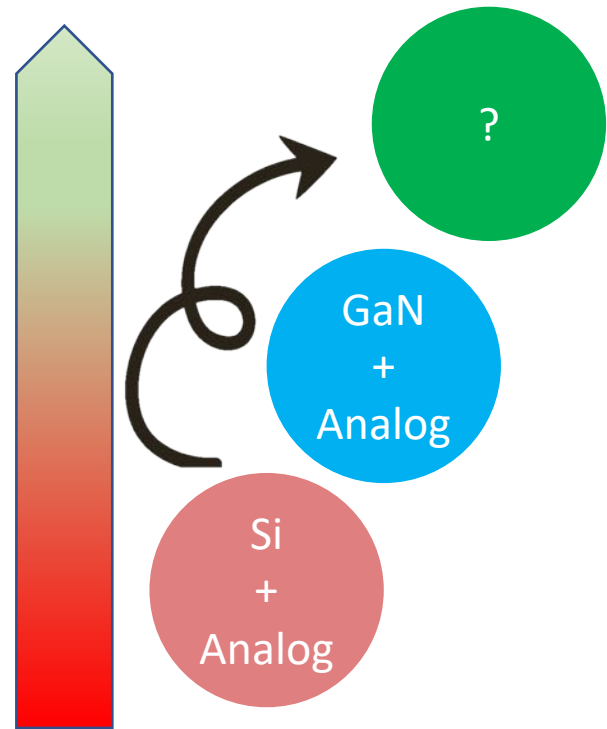

HOW TO MAXIMISE GAN PERFORMANCES & MARKET PENETRATION ?

DIGITAL CONTROL using MCU 32 bits activates the ultimate performances of GaN to answer ODMs & OEMs challenges

Regulation in real time to improve accuracy, response time and repeatability

→ **Increased efficiency and reduced distortion**

Flexible and programmable solution that could be customized

→ **Smart: monitoring, supervision**

Reduced number of components (no analog compensation component)

→ **Reduced BOM cost**

Simplified design and control

→ **Less development time as for silicon , accelerated GaN market penetration**

PFC Virtualization

→ **Better efficiency, Higher power density & reduced BOM cost**

Power Density

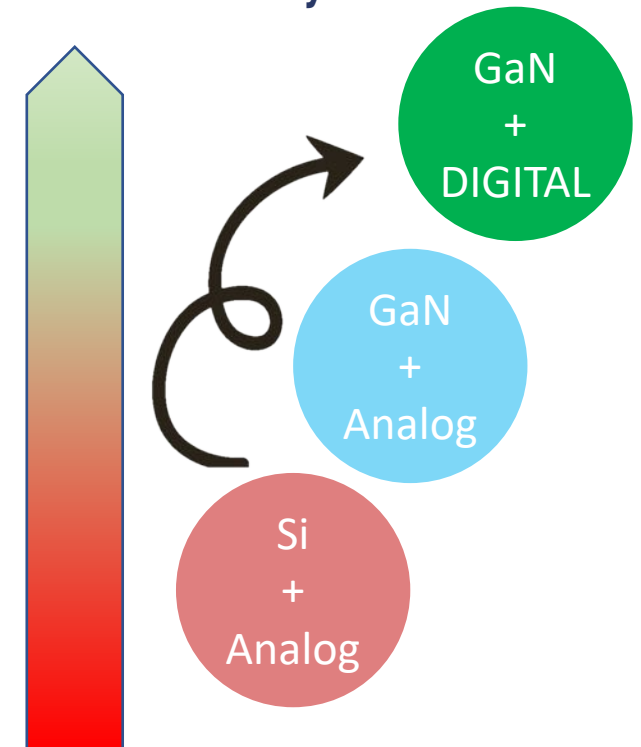

WE PROVIDE ADVANCED GaN POWER IC AND DIGITAL CONTROLLERS FOR THE POWER SUPPLY

AC/DC CONVERTER

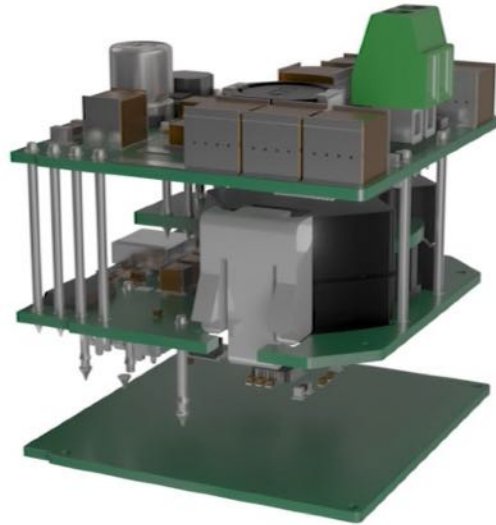

POWER BOARD with our GaN IC

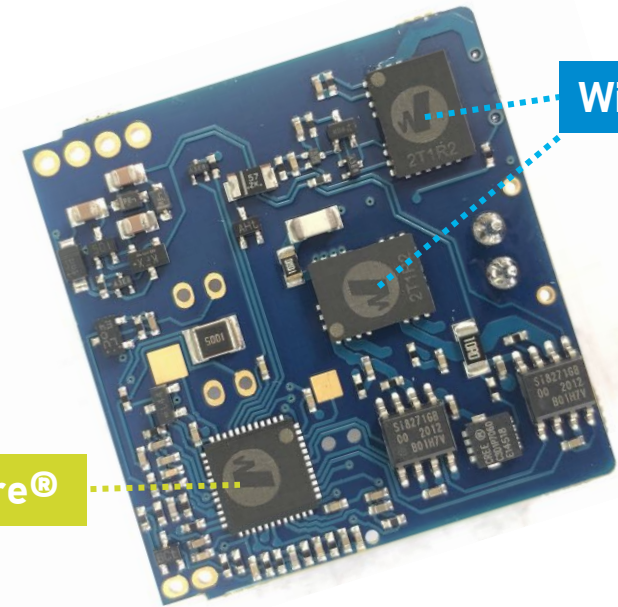
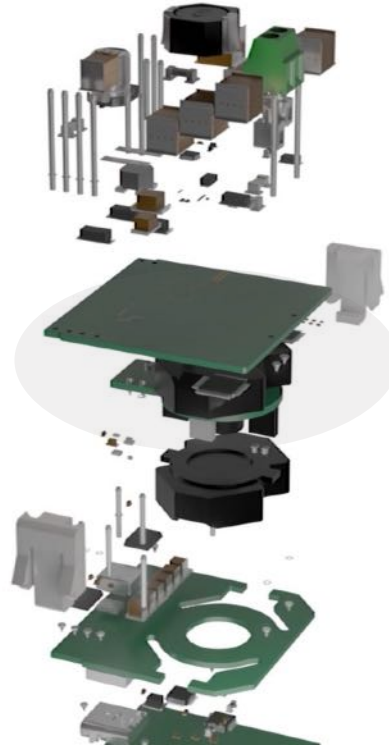

WiseGan®

WiseWare®

- WiseGan® = our GaN Power Integrated Circuit
- WiseWare® = our Digital Controller



AWARDS WINNING INNOVATOR
(2020, 2021 AND 2022)

i-Nov **i-Lab**
concours d'innovation

DIGITAL
IN PULSE

bpi**france**

AIRBUS
DÉVELOPPEMENT

STRONG FINANCIAL INVESTORS

leti
c22tech

SUPER
NOVA
INVEST

RÉGION SUD INVESTISSEMENT

COMPANY OVERVIEW

- Spin-off of CEA-LETI
- Founded in 2020
- 22 employees

Headquarters in France and
business office in Taiwan

Leading manufacturing partners:
TSMC wafer foundry
ASE packaging/testing

Patents portfolio (>10) & GaN Power
expertise



WISE INTEGRATION'S TARGET MARKETS

Consumer

- Fast chargers
- TV
- Power tools



HIGH POWER DENSITY (SMALL & POWERFULL)
30W to 7kW

E-mobility

- E-bike & E-scooter
 - E-motorcycle
- EV Onboard charger
(≥ 3 kW)



Industry

- Robotics
- Led driver
- Home Appliances
- Motor Control,
- Solar Inverter



HIGH POWER EFFICIENCY
300W to 7kW

Data center

- Data Com
- Telecom
- Enterprise



WISE INTEGRATION'S INNOVATIVE SOLUTION

We combine advanced GaN IC (WiseGan®) with digital control (WiseWare®) to activate the ultimate power supply performances

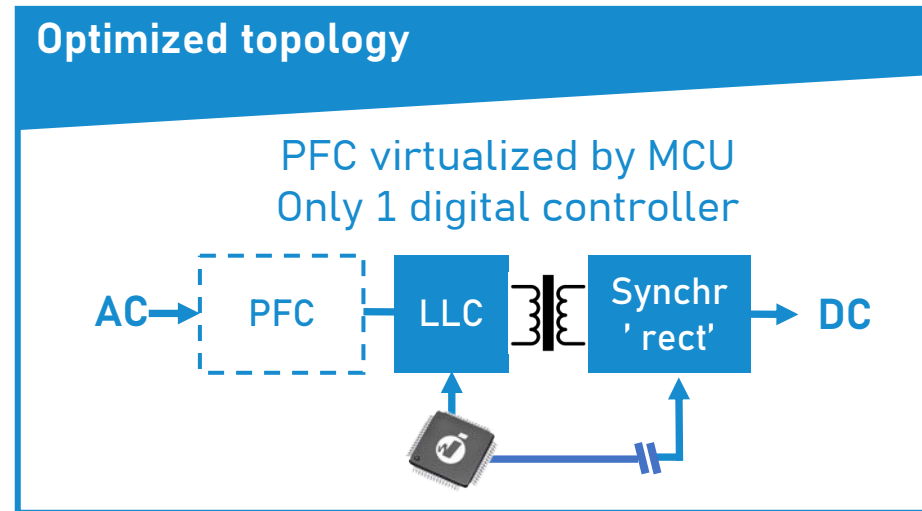
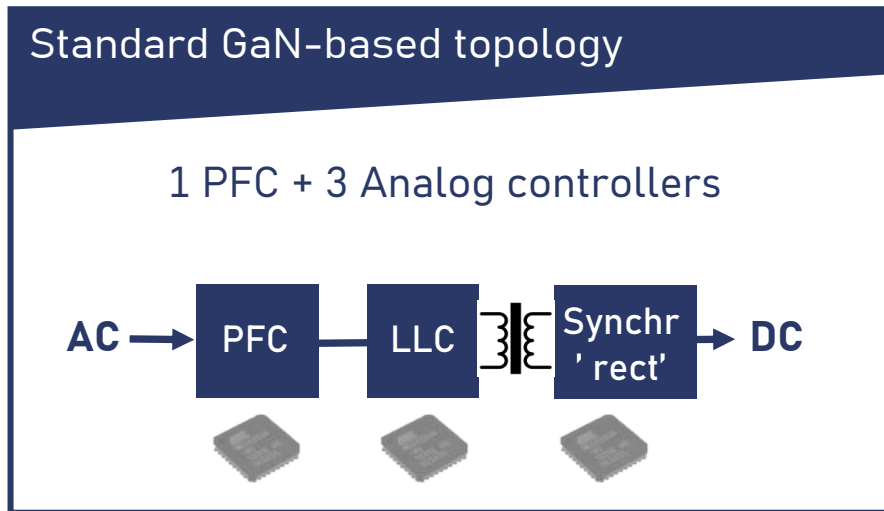

A patented solution

Key advantages

- **WiseGan®** is a GaN IC device designed by Wise Integration and manufactured on the 650V e-mode TSMC technology that incorporates innovative functions to be compatible with direct MCU drive.
- **WiseWare®** is the digital controller: a standard 32-bit MCU with a proprietary firmware.
- Improved power density (+33%) to reach the best power supply form factor
- BoM cost reduced by 10%
- Reduced development time



WISEWARE® ADDED VALUE VS. OTHER GAN-BASED SOLUTIONS

Benefits of WiseWare® digital control over analog control - 150W Power supply example

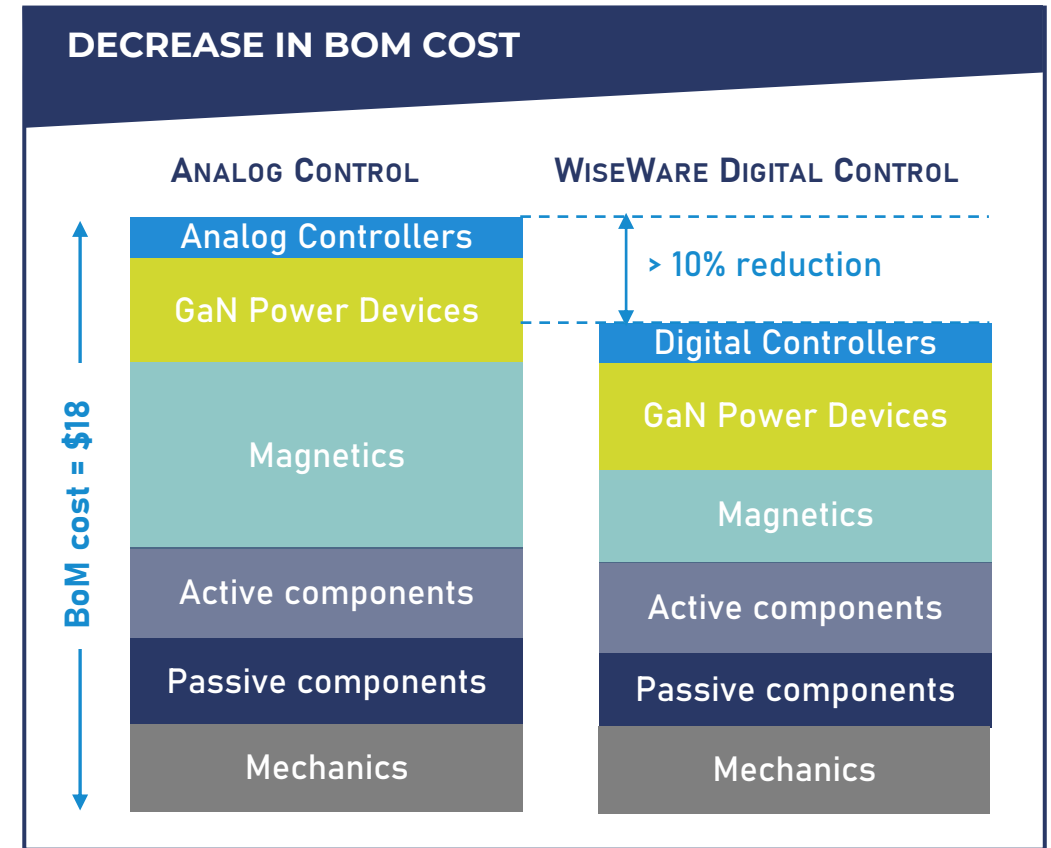
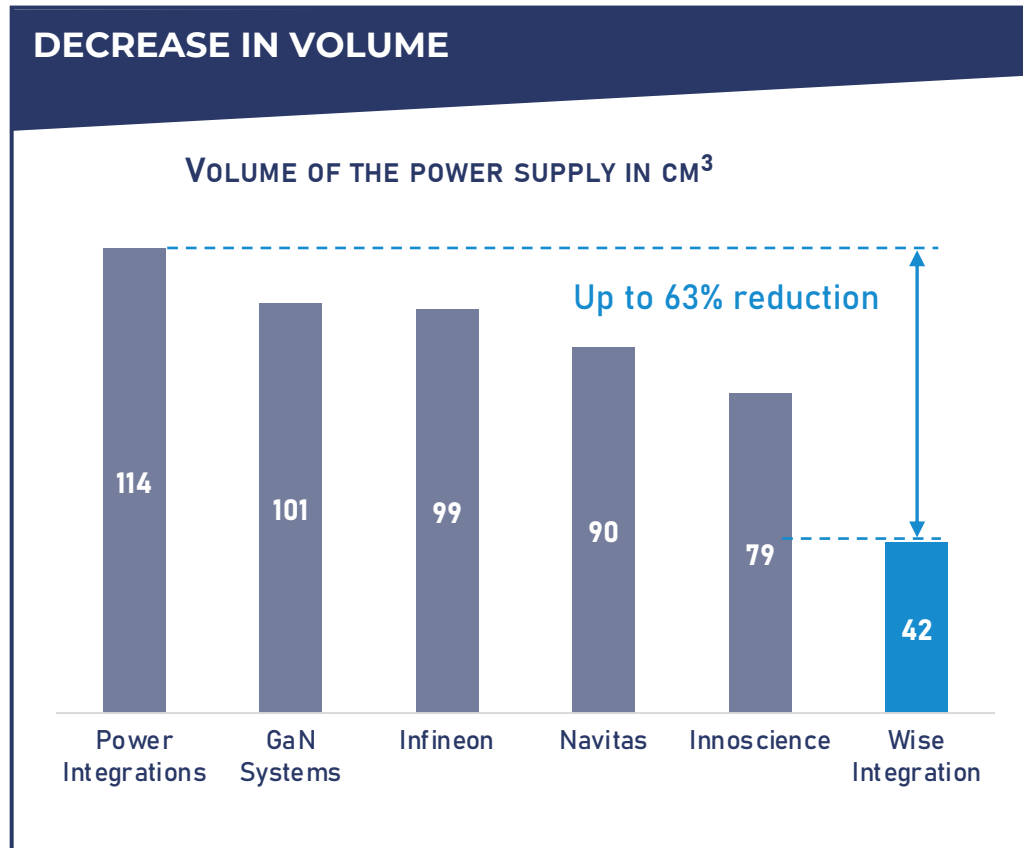

WiseWare® benefits

- 2.0x power efficiency (4.5W loss vs. 9.0W with analog control)
- Improved power density (>50%) leading to higher compacity
- BoM cost reduced by over 10% (\$16 vs. \$18)

PRODUCT ROADMAP AND MARKET APPLICATIONS

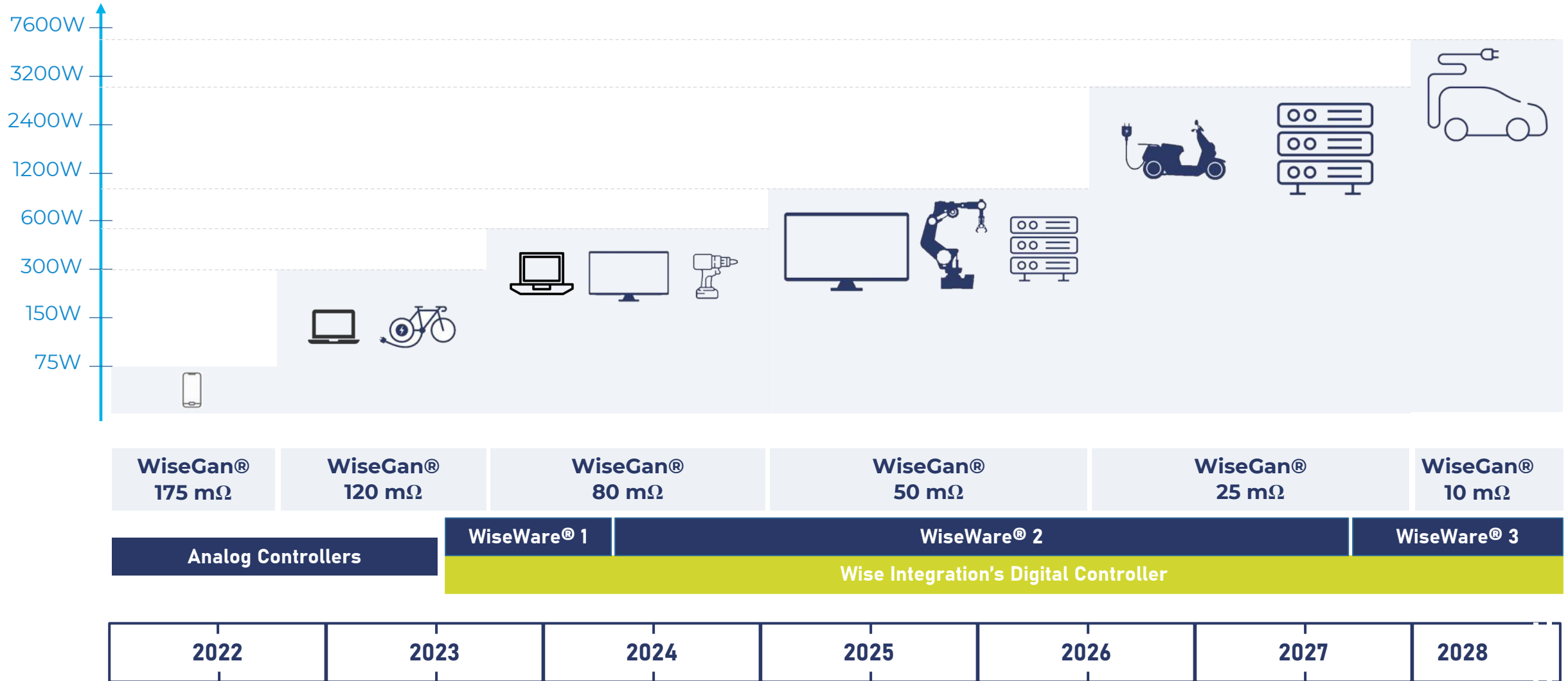

WISEGAN® IS LINKED TO WISEWARE®

Using standard GaN devices



Using WiseGan®

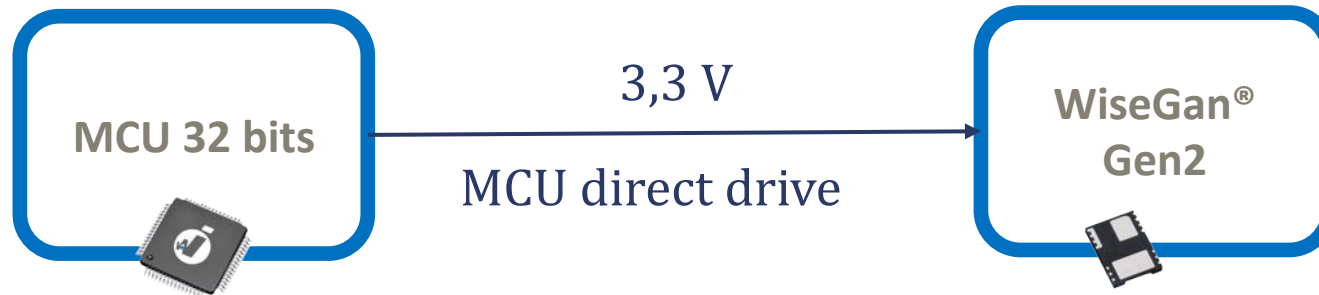

The WiseWare® algorithm increases system efficiency & BOM by using the internal WiseGan® properties accordingly



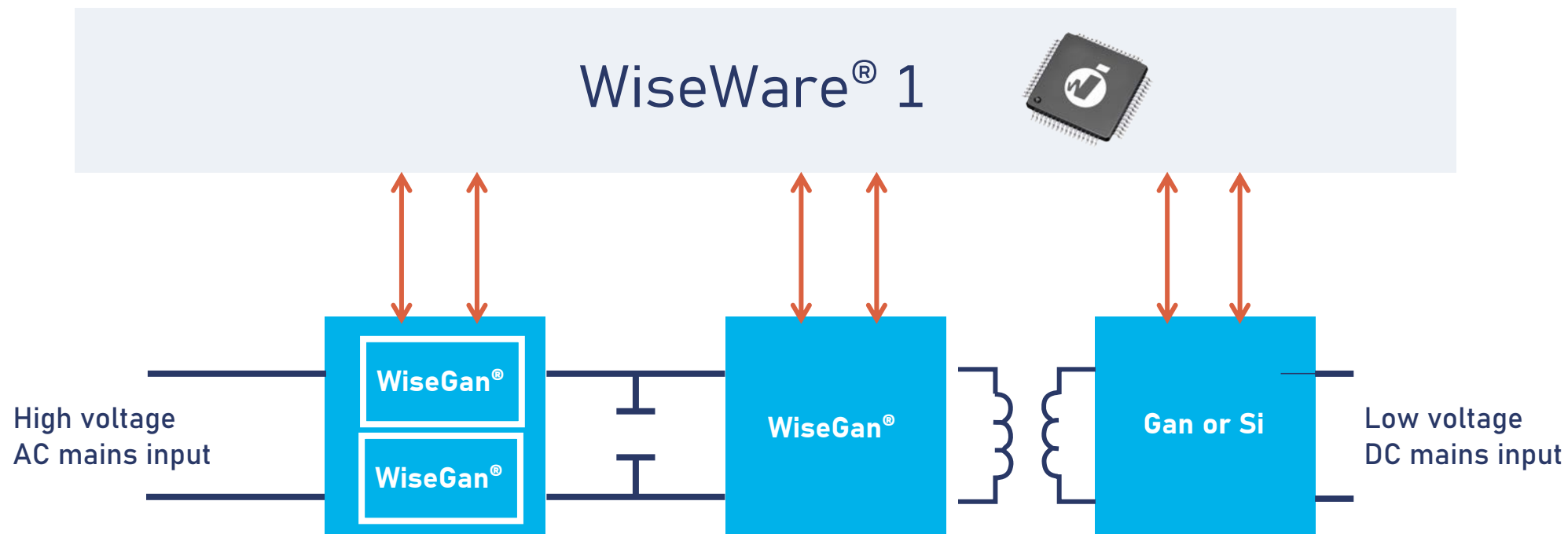

300W Demoboard v1

- PFC-LLC
- Digital control = 1 MCU
- Output: 20V
- 96% efficiency @ 300W

300W Demoboard v2

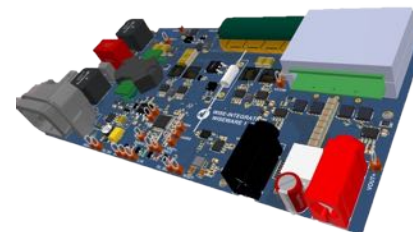

Totem Pole PFC LLC converter

- Totem Pole reduces BOM and energy losses on the mains side
- LLC converter allows for low loss switching
- Synchronous secondary rectification reduces losses on the output side
- WiseWare 1 Digital control

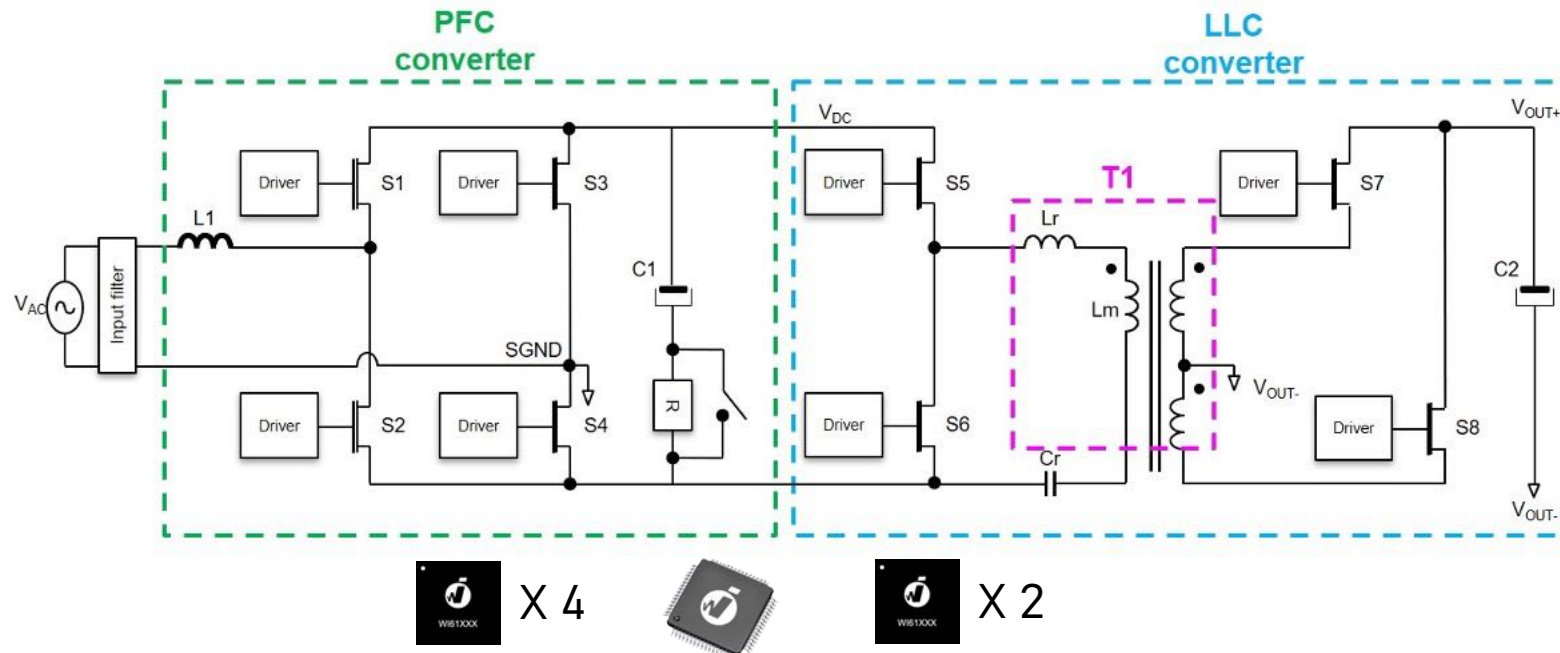

WiseWare® 2

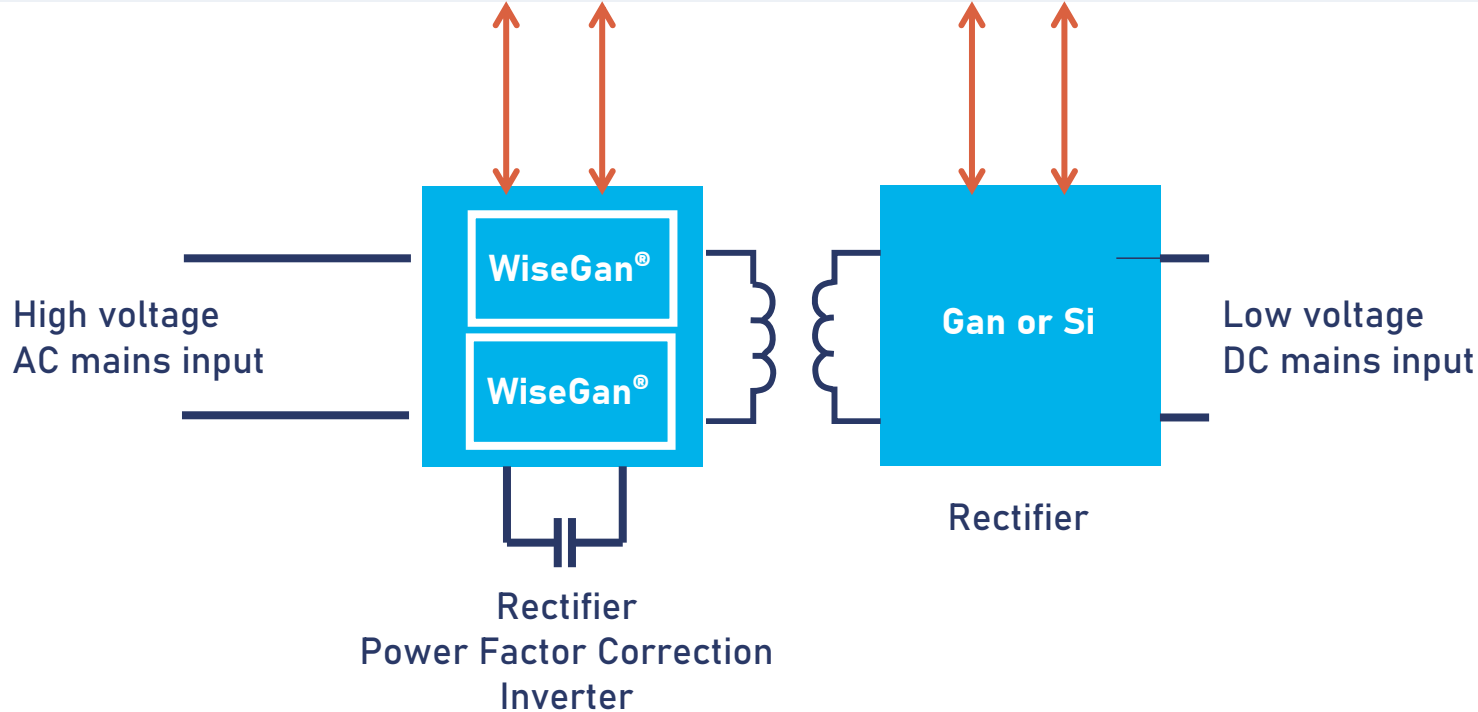

WISEWARE® 2 ELECTRICAL SCHEMATIC

Proprietary architecture (patented)

- Single input stage reduces BOM and energy losses on the mains side
- Synchronous secondary rectification reduces losses on the output side
- WiseWare® 2 Digital control

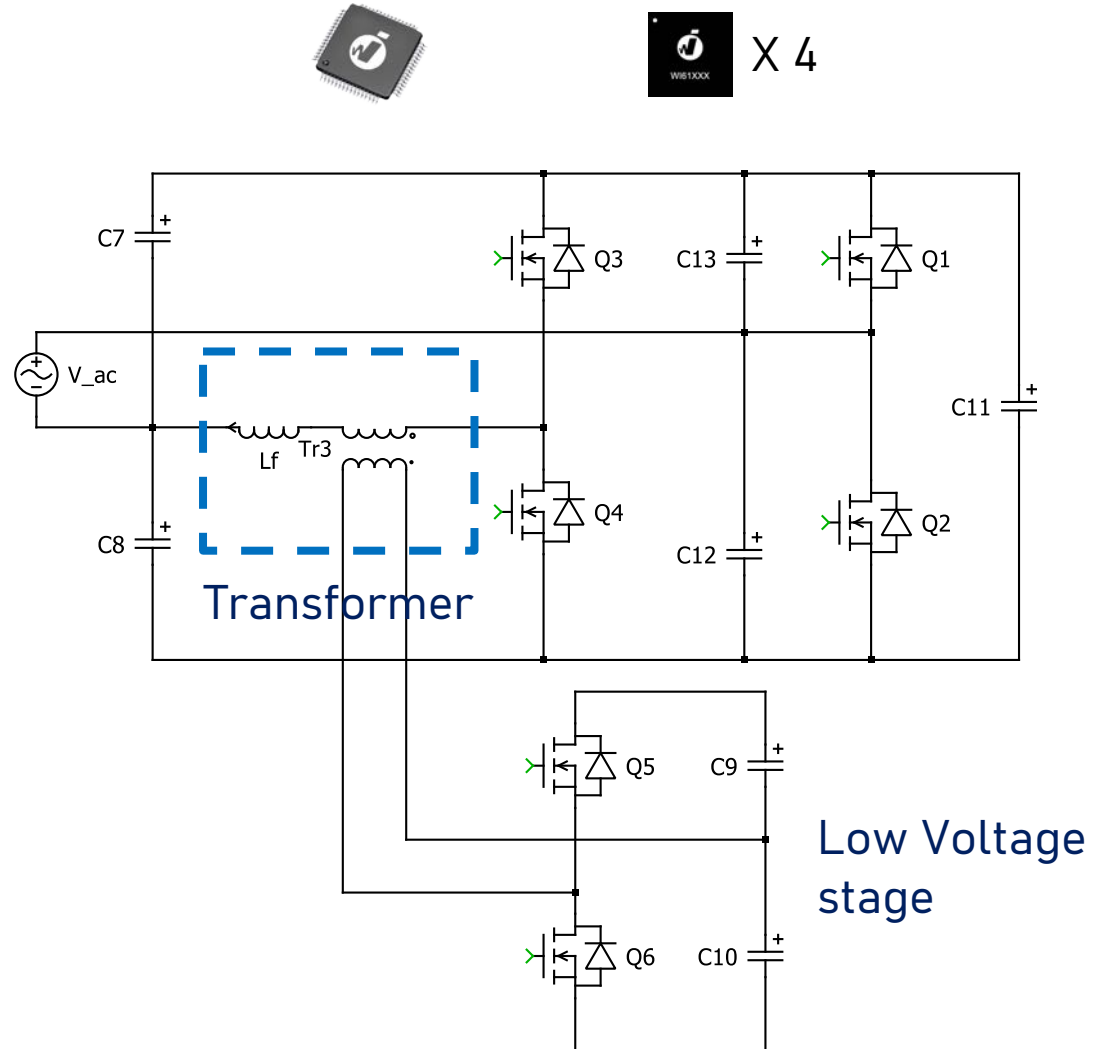

A TEAM OF 22 INDIVIDUALS, INCLUDING THE FOLLOWING MANAGERS



Thierry BOUCHET
CEO, Co-founder



Pascal LE DEU
COO



Florian COUVIN
Regional VP Sales
Co-founder



Dominique BERGOGNE
CTO, Co-founder



Gérald AUGUSTONI
VP Marketing App



Bernard BANCAL
Product Director



Rym HAMOUMOU
Chief Corp Marketing &
Strategic Communication
Co-founder



22 People

12 R&D engineers

1 Manufacturing & Operations

5 Sales & Marketing

4 Management & Admin



WISEWARE®: DEDICATED FULL DIGITAL AC-DC CONTROLLER FOR GAN BASED POWER SUPPLY



MAIN FEATURES

- Dedicated to Gan, leverages the best value of GaN transistors
- Fully digital, will benefit from future technological drop
- Quick release of new versions and evolutions
- Adaptable to different digital engines
- Qualified firmware standardization supporting main topologies
- Proprietary enhanced topology versions
- Optimized timing, frequency and deadtime
- Real-time computed system model for predictive behavior
- High-level communication for system supervision



KEY ADVANTAGES

- Optimize performance with GaN
- State of the art power density
- Reduced components count and cost
- Simplified debugging through communication
- Validation on a standardized turnkey system
- Fast time to production
- Improved reliability





THANK YOU

wise-integration.com

EUROPE

HEADQUARTERS

87 rue Philémon Laugier
83400 Hyères

R&D

11 chemin du Vieux Chêne
38240 Meylan

ASIA

TAÏWAN

2F, 19 Fuguo Road, Taipei
111079, Taiwan